

RECOMMENDED PCB LAYOUT
GENERAL TOLERANCE ±0.05

NOTES:

1. MATERIAL:
 - 1.1 HOUSING: THERMOPLASTIC, HIGH TEMP., UL94V-0; COLOR:BLACK.
 - 1.2 CONTACT: COPPER ALLOY
 - 1.3 FITTING NAIL : COPPER ALLOY
2. FINISH:
 - 2.1 CONTACT:
 - 50~100u" NICKEL UNDERPLATING OVERALL
 - 1: GOLD FLASH PLATED ON CONTACT
 - 2.2 SOLDER:
 - 50~100u" NICKEL UNDERPLATING OVERALL
 - 1: GOLD FLASH PLATED ON SOLDER AREA
 - 2.3 FITTING NAIL:
 - 50~100u" NICKEL UNDERPLATING OVERALL
 - 50~120u" MATTE TIN PLATING OVERALL.
3. REFLOW SOLDER CAPABLE TO 260°C PER ACES SPEC.
4. WAVE SOLDER CAPABLE TO 260°C PER ACES SPEC.
5. SPEC. PLS. REFER TO PS-50975-xxxx-xxx
6. PACKAGE PLS. REFER TO 53040-xxxx-TRP

7. PART NUMBER

P/N LEGEND

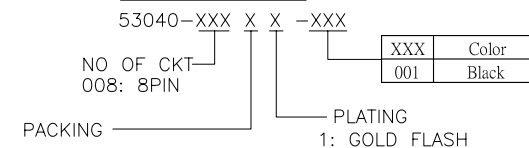

7:TAPE & REEL WITH COVER

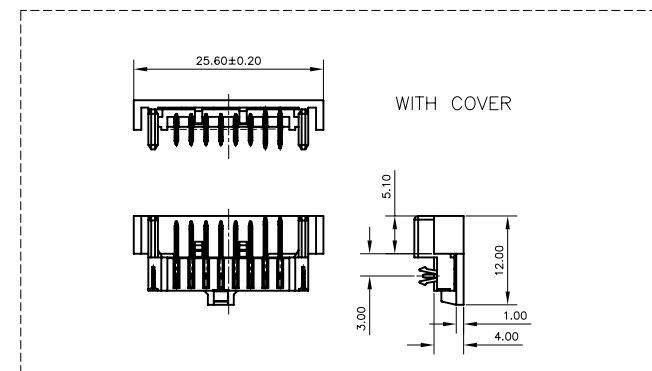

一般公差 TOLERANCES X. ±0.5 XX ±0.15 X ±0.25 XXX ±0.1 ANGLES ±2°	宏致電子股份有限公司 Aces Electronics Co.,Ltd.	
檢驗尺寸標示 SYMBOLS ① ② INDICATE CLASSIFICATION DIMENSION ① MARK IS CRITICAL DIM. ② MARK IS MAJOR DIM.	品名 (TITLE) 2.0mm BATTERY CONN. Male DIP R/A Type H=2.75mm 圖號 (DWG NO.) 53040-XXXXX-XXX	製圖 (DR) 許紅星 '12/11/19 審核 (CHKD) CARL 核准 (APPD) Jason
表面處理 (FINISH)	比例 (SCALE) 1:1	單位 (UNITS) mm
	張數 (SHEET) 1 OF 1	SIZE A4
		REV 0